



The MNSSR system is the advanced add-on solution that brings rapid shutdown functionality to one or two standard PV modules.

RECEIVERS

MNSSR (MidNite Sunspec Receiver) This is a single panel receiver. Intended application is module level shut off. 12 amp / 80 volt panels max. 80C max

MNSSRD MidNite Sunspec Alliance MNSSR and MNSSRD are advanced add-on solutions that brings rapid shutdown functionality to one or two standard PM Modules.

MNSSR-600S (MidNite Sunspec string level Receiver) This is a receiver that connects to a string of panels up to 600V max. 12 amps. 80C max ambient.

MNSSR-600S-SIC (MidNite Sunspec string level Receiver) Same as above, but can operate in an 85C ambient.

MNSSR-1000S (MidNite Sunspec string level Receiver) This is a receiver that connects to a string of panels up to 1000V max. 12 amps. 80C max ambient.

TRANSMITTERS

MNSST-Single (MidNite Sunspec Transmitter) Single toroid made for up to 6 strings. The transmitter comes in a din rail mount housing. Operates from a 12-16VDC source. Strings can be anywhere from one panel to a 1000V string.

MNSST-Dual (MidNite Sunspec Transmitter) Double toroids made for up to 12 strings. The transmitter comes in a din rail mount housing. Operates from a 12-16VDC source. Strings can be anywhere from one panel to a 1000V string.

MNSST-Naked (MidNite Sunspec Transmitter board assembly) This transmitter comes with one toroid. One or two strings may be run through the sensor. This transmitter is a field installed option used only inside the MidNite Hawke's Bay and Barcelona MPPT solar charge controllers.

Maximum system voltage:	1000V
Maximum voltage per input:	80V
Maximum current per receiver module:	12A
Maximum output power:	500W single, 1000W double

Use ANSI/NFPA 70 wiring methods.

Requires Sunspec Certified Transmitter for rapid shutdown control.
Output voltage is 1.0V when RSS Transmitter signal is not present.

Class II double insulation

High Voltage

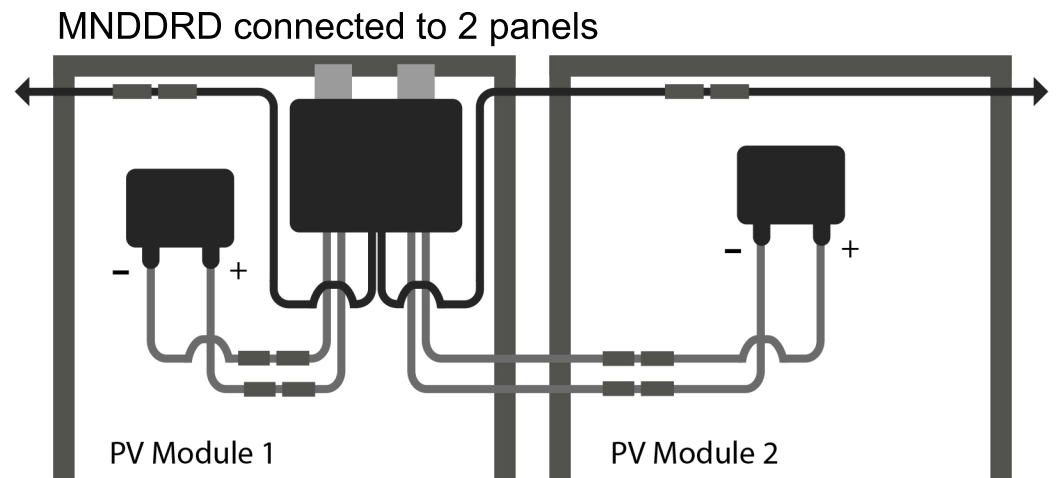

NOTE: When installing MNSSRD, always connect the input cables to the PV modules before connecting the MNSSRD output cables in series. If disconnecting MNSSRD, always disconnect the MNSSRD output cables from the string before disconnecting the input cables from the PV modules. All components in the system must carry the Sunspec certification label for ensured reliability.

MULTIVENDOR SOLUTIONS

MidNite will be one of numerous manufactures with Sunspec Certified module-level rapid shutdown solution. The installer has the freedom to choose functions based on their needs and the needs of their customers. Make sure the entire system is comprised of Sunspec certified components.

MODULES

MidNite's modular platform will be certified by INTERTEK (ETL) and Nationally Recognized Testing Laboratories (NRTL) for fully complying with the USA's National Electric Code (NEC) 690.12 Rapid Shutdown regulations with all PV modules. MidNite's platform has been successfully tested with multiple PV modules.

Inverters

MidNite's platform is a Sunspec certified MLPE RSS solution with multiple inverters from various inverter manufactures

MNSSR (Fire Safety) is a specialized rapid shutdown solution available as add-on unit MNSSR or MNSSRD. Rapid shutdown activation is controlled by power-line communication (PLC) with a certified RSS Transmitter. The RSS (Rapid Shutdown System) Transmitter, from MidNite or other Sunspec certified companies, completes the cost-effective rapid shutdown system architecture when paired with MidNite's MNSSR (single module) and/or MNSSRD (dual module) solutions. The RSS Transmitter sends a Sunspec certified signal to the receiving units to keep PV modules connected while powered on and supplying energy. MNSSR units automatically enter rapid shutdown mode when the Sunspec certified RSS Transmitter is switched off and resume energy production when power is restored to the RSS

RELIABLE MLPE FOR ARRAY SECURITY

To provide the best asset management for residential and commercial PV systems, MidNite offers a module-level safety solution. This function can be used for ordinary maintenance operations, as well as in emergency situations, intensifying the safety of the system. This revolutionary disconnect provides installers, firefighters, and maintenance techs absolute certainty that no high voltage is present.

MODULE-LEVEL DISCONNECT

MidNite's system includes a Sunspec certified advanced safety feature to shut down a PV array at the module-level, the safest way to de-energize a PV system. When shutdown mode is activated, the MidNite system disconnects the PV module from the string, leaving it with zero power output. This can be used for emergency situations of scheduled maintenance and can be activated manually or automatically.

Although the USA currently has the strictest solar electric codes, other countries are quickly following with the similar requirements to protect solar assets and system owners. MidNite is the only Sunspec certified module **and string level** rapid shutdown solution that meets the latest requirements.

TEN SECONDS PER MODULE

Each MNSSR connects to the PV module at the junction box and clips to the module frame. Plug and play with your PV system.

NO GROUND WIRE REQUIRED

MidNite receivers do not need a separate ground wire or mounting bolts for installations.

WATER AND CORROSION RESISTANT

Polycarbonate cover is water-resistant to 1.5m deep – proven in the harshest environments from Antarctica to the Atacama desert.